

WR6609 | WR6609S | WR6609V

The WR Series wall mounted cabinets are built to the highest standards. More than 30 different size and door variations makes the WR Series one of the most comprehensive in the market. The fully welded frame ensures a stable structure while the key lockable quick release door opens to 180° degrees. Doors are available in Acrylic, Steel or Curved Vented.

Features

- > Fully welded frame ensures a stable structure
- > Quick release door hinges
- > Reversible doors open to 180° degrees
- > Vented doors are curved with 70% perforation (protrudes 50mm)
- > 4 x Adjustable mounting rails
- > Top and bottom panel with multiple cable entry knockouts
- > Removable rear panel
- > Quick Mount Rail aids mounting of cabinet

Standard Inclusions

- > Acrylic front door is standard (Steel and Vented doors are supplied separately)
- > 1 x Cantilever shelf (1RU 300mm deep)
- > Key lock on front door
- > Key locks on removable side panels
- > Cable entry knockouts top, bottom and rear
- > Fan vents on top
- > Front and rear 19" mounting rails with RU markings
- > Earthstud
- > 25 cage nuts and screws
- > Quick Mount Rail



Acrylic Door – WR6609 (Standard)



Steel Door – WR6609S



Vented Door – WR6609V

| Part No. | RU  | Height mm | Width mm | Depth mm | Colour | Door    | Description                             |
|----------|-----|-----------|----------|----------|--------|---------|---|
| WR6609   | 9RU | 500       | 600      | 600      | Black  | Acrylic | WR Cabinet – 9RU 600w 600d Acrylic Door |
| WR6609S  | 9RU | 500       | 600      | 600      | Black  | Steel   | WR Cabinet – 9RU 600w 600d Steel Door   |
| WR6609V  | 9RU | 500       | 600      | 600      | Black  | Vented  | WR Cabinet – 9RU 600w 600d Vented Door  |



Acrylic Door

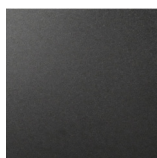

Steel Door

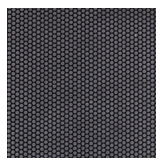

Curved Vented Door

### Technical Specifications

**Description:** WR Cabinet – 9RU 600w 600d

**Cabinet Dimension:** 500h X 600w X 600d

**Colour:** Black

**Weight:** 20kg

**Shipping Dimension:** 540h x 640w x 640d

**Shipping Weight:** 23kg



Removable rear panel

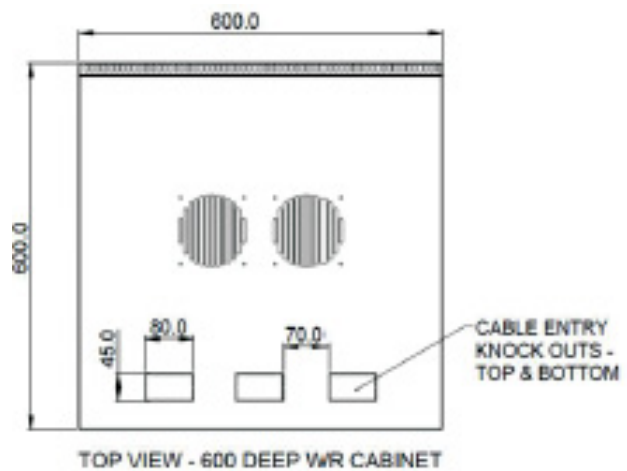
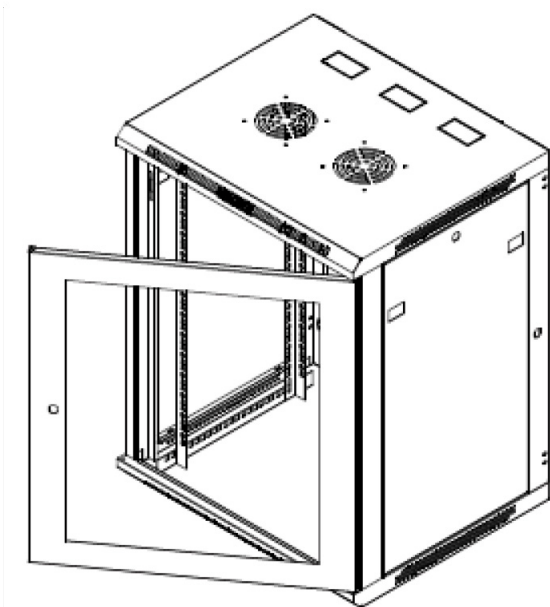

Information contained in this document is accurate at the time of preparation and is provided in good faith for general guidance. The information should not be used for detailed design or final specification as it is subject to change without notice. Please contact your local Racktech sales representative or the Racktech customer support team to obtain a copy of the current technical specifications. Images are for illustration purposes only.

March 2021